

**Z-Line Tire Rack - Adder**

RETAIN INSTRUCTIONS FOR FUTURE REFERENCE!

---

Congratulations on your purchase of a Z-line Tire Rack from Tennsco! Z-Line's interlocking keyhole design not only makes installation fast and easy, but eliminates the need for clips, gussets, sway braces or other hardware commonly used in conventional shelving.

Tennsco uses sturdy steel construction for strength and durability. Our attractive and durable powder-coated paint finish will provide years of service.

**NOTE: Units are designed to store tires ONLY!  
Not designed for tires on mounted wheels.**



**GENERAL SAFETY INFORMATION**

Some parts may have sharp edges. CARE must be taken when handling various pieces to avoid injury. For safety, wear a pair of work gloves when assembling or performing any maintenance on shelving.

---

**LIMITED WARRANTY**

Tennsco warrants goods purchased hereunder to be free of defects in materials and workmanship for a period of one (1) year from the date of shipment, hereunder. This warranty shall not apply in the event goods are damaged as a result of misuse, abuse, neglect, accident, improper application, modification or repair by persons not authorized by Seller, where goods are damaged during shipment, or where the date stamps on the goods have been defaced, modified or removed. UNLESS CONSIDERED UNENFORCEABLE OR UNLAWFUL UNDER APPLICABLE LAW:

- a. ALL IMPLIED WARRANTIES, INCLUDING BUT NOT LIMITED TO WARRANTIES OR MERCHANTABILITY AND FITNESS FOR A PARTICULAR PURPOSE ARE HEREBY EXCLUDED:
- b. BUYERS REMEDY, IF ANY, FOR ANY DEFECTIVE GOODS SHALL BE LIMITED TO A REFUND BY SELLER OR REPLACEMENT OF THE GOODS AT SELLER'S OPTION, AND SHALL IN NO EVENT INCLUDE DAMAGES OF ANY KIND, WHETHER INCIDENTAL, CONSEQUENTIAL OR OTHERWISE.

NO GOODS ACCEPTED FOR RETURN WITHOUT PRIOR APPROVAL. Seller shall have the right to inspect any goods claimed to be defective at Buyers place of business or require Buyer to return the goods to Seller for inspection on Seller's premises. Transportation charges covering returned goods will be borne by Seller only if such goods are proven to be defective, are covered by this warranty and are returned within the warranty period stated above.

---



**PROUDLY MADE IN THE U.S.A.**

Tennsco Corp., Dickson, TN 37056-1888 • (615) 446-8000

# **ASSEMBLY OF TIRE RACK - ADDER**

Two people are recommended for assembly. Approximate assembly time: 25-35 minutes.

**1.** The reference numbers used throughout this sheet refer to the illustration on the back cover. This is to help you to identify the various parts as they are mentioned.

**2.** Adder units are to be connected to an existing starter unit. Unassemble your starter unit by removing the left-to-right channel supports.

**3.** Laying flat on the ground, connect two ZTP upright (Ref. No. 1) posts together with two front-to-back supports (Ref. No. 2), one at the top and one near the bottom, leaving the bottom keyhole slot empty. Be sure the supports are fully seated in the slots.

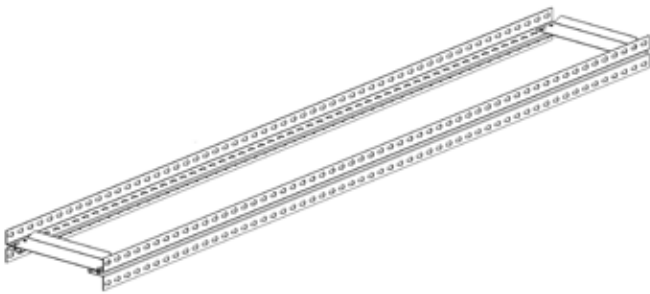

**4.** Place the remaining front-to-back support(s) evenly along the uprights.

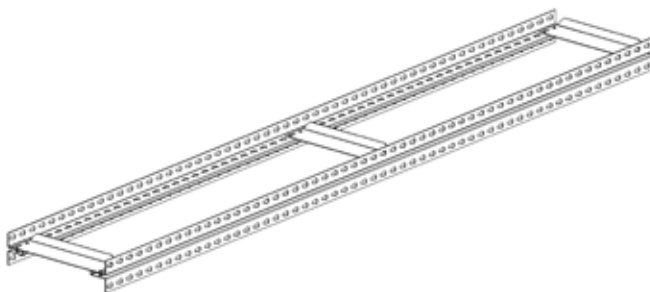

**5.** With the help of an associate, raise one EUR upright set (from starter unit) and the ZTP upright set and connect them with left to right channel beams (Ref. No. 3). Be sure the channel beams are fully seated.

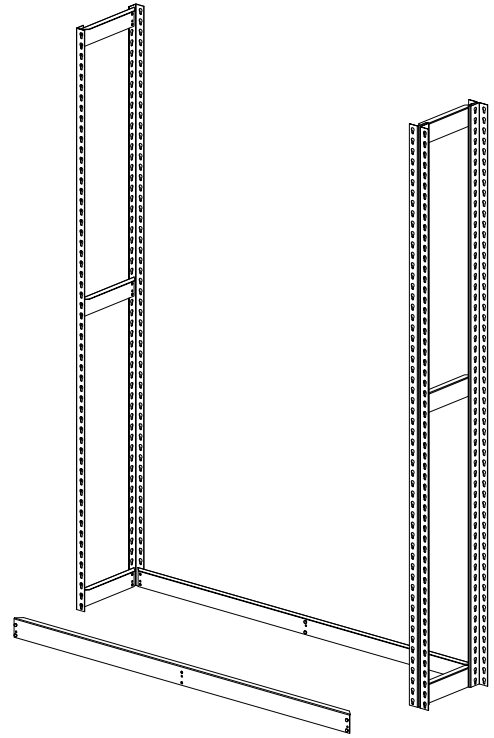

**6.** Continue to build your shelf levels by placing left to right channel beams at the desired locations.

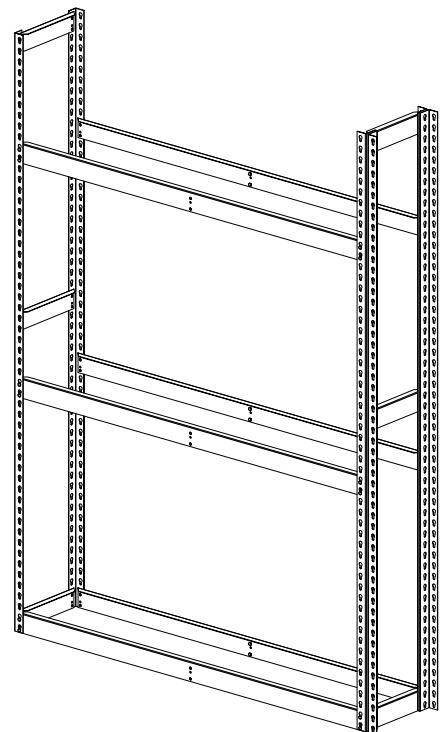

7. With the help of an associate, raise the remaining EUR upright set (from starter unit) and the ZTP upright set and connect with left to right channel beams. Be sure the channel beams are fully seated.

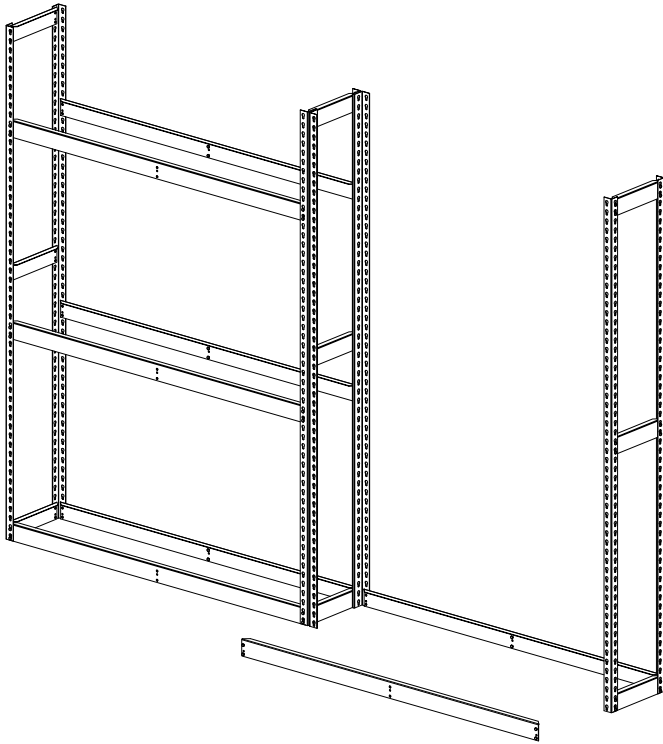

8. Continue to build your shelf levels by placing left to right channel beams at the desired locations.

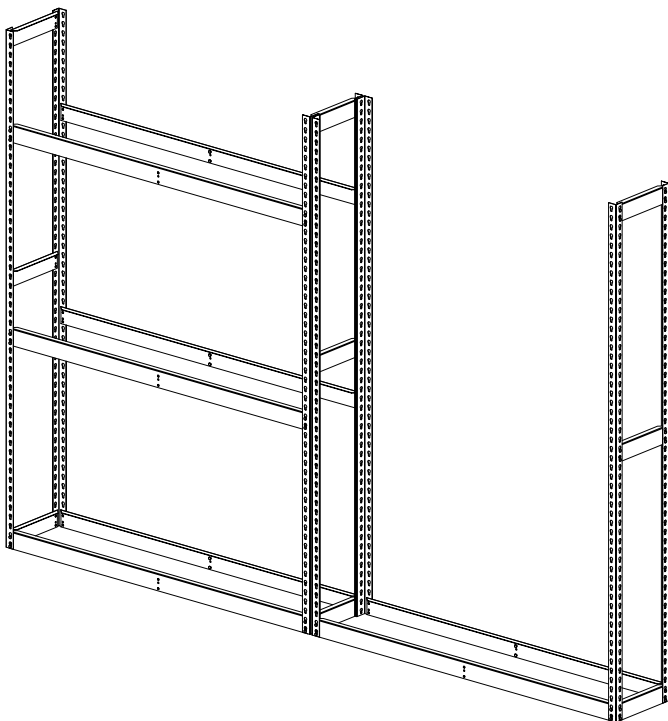

### **For Single Entry Units**

- 9a. Attach the wall tie to the top of the unit on the left, right and middle posts at the back of the unit. Taller units require additional wall ties (included), for support.

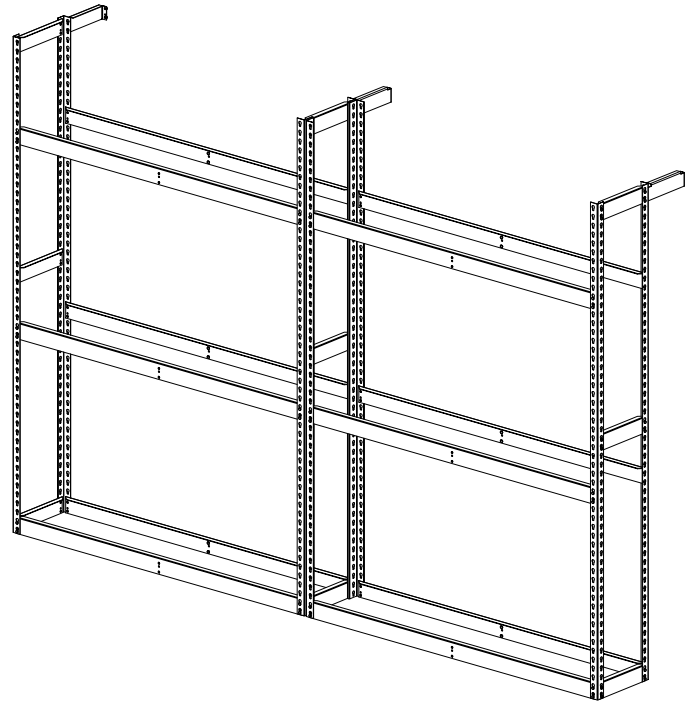

**NOTE: Wall Ties are REQUIRED to be used for unit stability on Single Entry Units.**

### **For Double Entry Units**

- 9b. Assemble your second unit by following the same steps listed. Attach the cross aisle ties to the top and bottom of the left, right and middle posts.

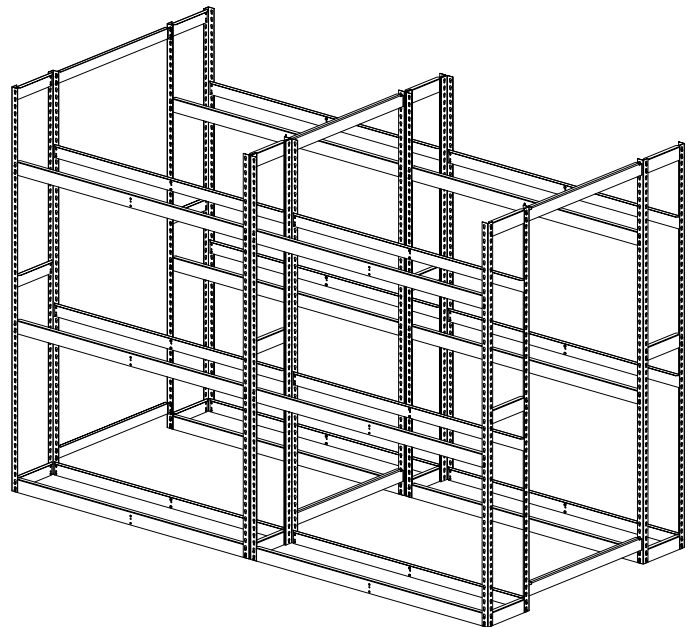

# REPLACEMENT PARTS

REF. NO.	DESCRIPTION	PART NO.	QTY.
<b>SINGLE ENTRY UNITS</b>			
<b>ZST-6060A</b>			
1	Upright Post	ZTP-60	2
2	Shelf Support (12"W)	LRA-12	3
3	Shelf Support (60"W)	LRA-60	4
4	Wall Tie	WT-9	1
<b>ZST-6084A</b>			
1	Upright Post	ZTP-84	2
2	Shelf Support (12"W)	LRA-12	3
3	Shelf Support (60"W)	LRA-60	6
4	Wall Tie	WT-9	1
<b>ZST-60120A</b>			
1	Upright Post	ZTP-120	2
2	Shelf Support (12"W)	LRA-12	4
3	Shelf Support (60"W)	LRA-60	8
4	Wall Tie	WT-9	3
<b>ZST-60144A</b>			
1	Upright Post	ZTP-144	2
2	Shelf Support (12"W)	LRA-12	5
3	Shelf Support (60"W)	LRA-60	10
4	Wall Tie	WT-9	6
<b>DOUBLE ENTRY UNITS</b>			
<b>ZDT-6060A</b>			
1	Upright Post	ZTP-60	4
2	Shelf Support (12"W)	LRA-12	6
3	Shelf Support (60"W)	LRA-60	8
4	Cross Aisle Tie	CAT-18	2
<b>ZDT-6084A</b>			
1	Upright Post	ZTP-84	4
2	Shelf Support (12"W)	LRA-12	6
3	Shelf Support (60"W)	LRA-60	12
4	Cross Aisle Tie	CAT-18	2
<b>ZDT-60120A</b>			
1	Upright Post	ZTP-120	4
2	Shelf Support (12"W)	LRA-12	8
3	Shelf Support (60"W)	LRA-60	16
4	Cross Aisle Tie	CAT-18	2
<b>ZDT-60144A</b>			
1	Upright Post	ZTP-144	4
2	Shelf Support (12"W)	LRA-12	10
3	Shelf Support (60"W)	LRA-60	20
4	Cross Aisle Tie	CAT-18	2

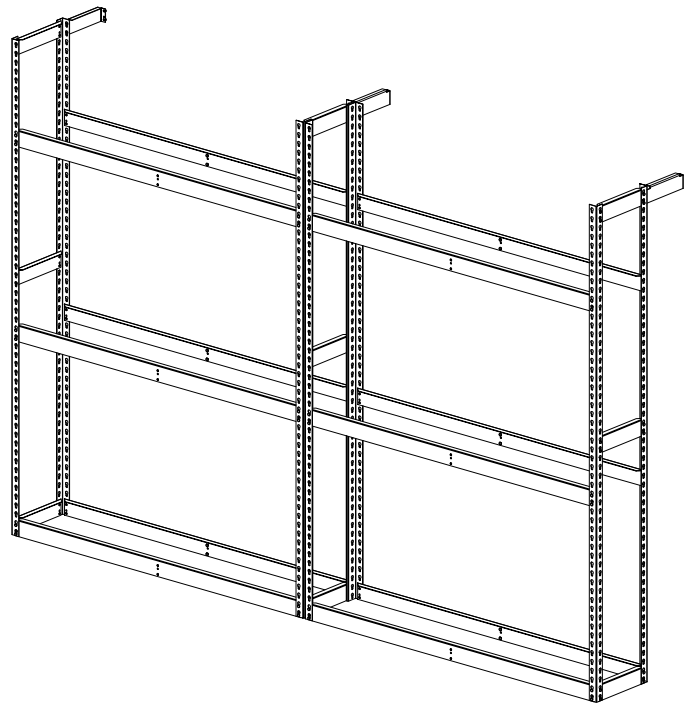

.....

Tennsco makes every effort to ensure that all units ship complete with all parts and arrive undamaged. However, should your unit contain missing or damaged parts, please contact your purchase location.

.....